

| FLANGE FACING AND DRILLING | | | | | | | | |
|----------------------------|----------|-------|----|------|-----|----|------|-------|
| VALVE | FLANGE | D | G | T* | R | N | B | C |
| M40T (OA=40) | PN40 | 150 | 88 | 18 | 3 | 4 | 18 | 110 |
| | ASA 125 | 127 | - | 18 | - | 4 | 16 | 98.4 |
| | ASA150 | 127 | 73 | 18 | 1.6 | 4 | 16 | 98.4 |
| | ASA300 | 155.6 | 73 | 18 | 1.6 | 4 | 22.2 | 114.3 |
| | TAB" D&E | 133.4 | - | 12.7 | - | 4 | 14.3 | 98.3 |
| | PN/6 | 130 | 80 | 14 | 3 | 4 | 14 | 100 |
| PN 10/16 | 150 | 88 | 16 | 3 | 4 | 18 | 110 | |

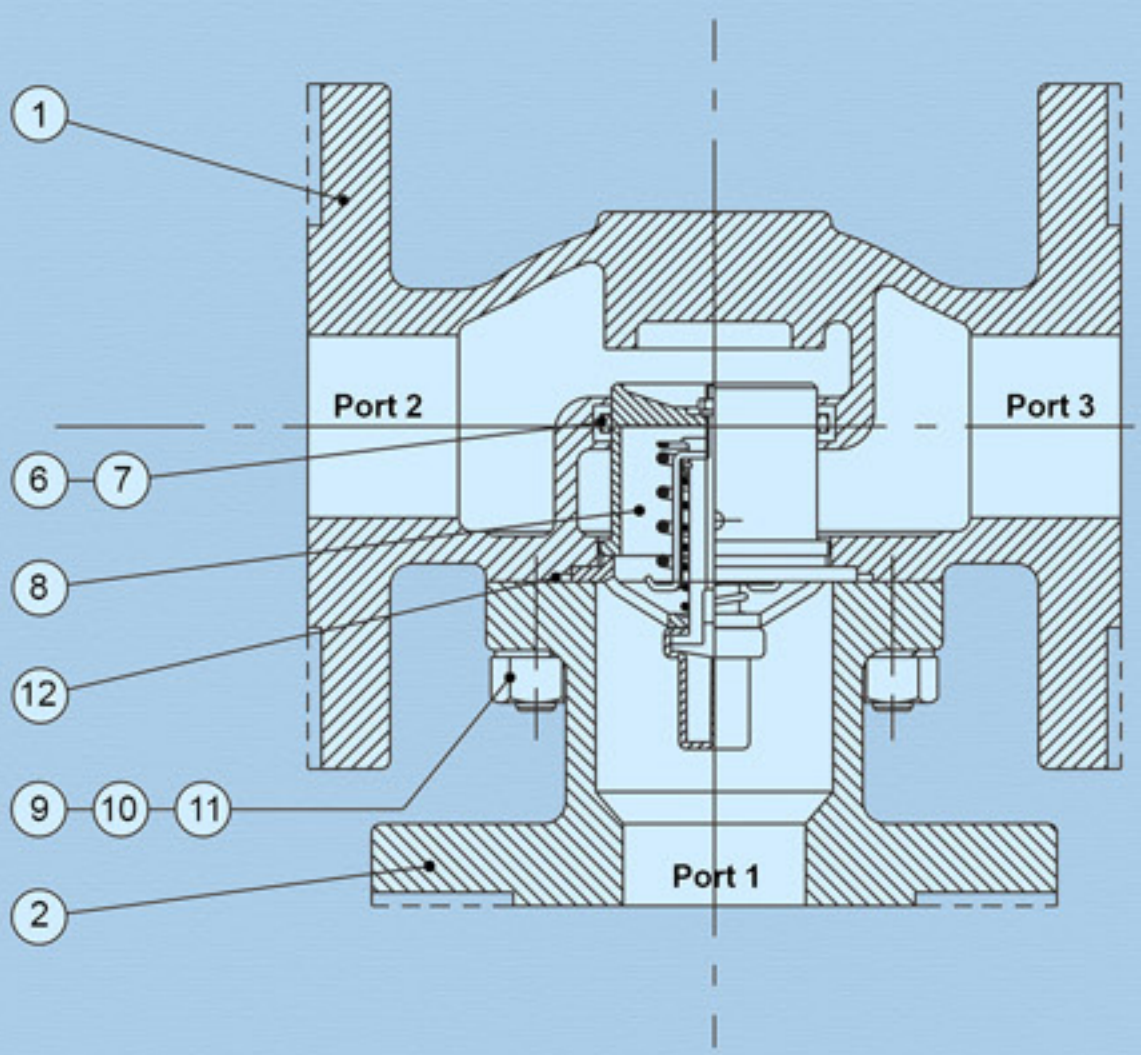

SG & CAST IRON VALVES NORMALLY SUPPLIED WITH FLAT FACE FLANGES.
*FLANGE THICKNESS 18mm FOR ALL VALVE TYPES

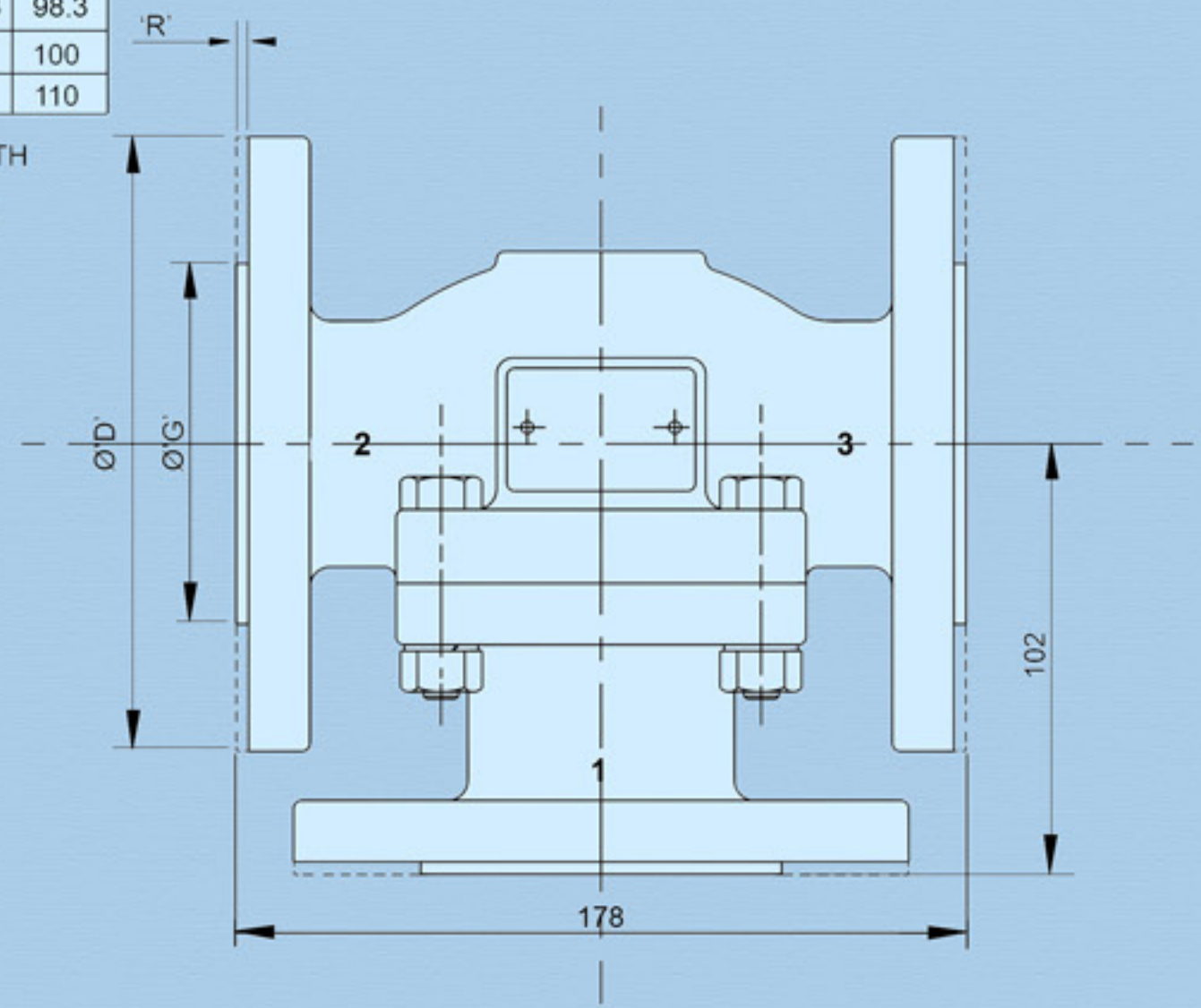

| No. | DESCRIPTION | CHK'D | APP'D | DATE |
|-----|-------------|-------|-------|------|
| | | | | |

TITLE
ASSEMBLY M40T STANDARD
THERMORÉG PRODUCTS LTD. MILDENHALL SUFFOLK Eng.

TOLERANCES
BASIC MM +
ONE DEC PLACE +
TWO DEC PLACE +
MATERIAL

| | | | | | |
|------------------|--------|---------|----------|------|--------------|
| DRAWN M.Frost | TRACED | CHECKED | APPROVED | DATE | SCALE 1:3 |
|------------------|--------|---------|----------|------|--------------|

DRAWING No. 3184